

Measuring relay
MMA - Phase measuring relay / Asymmetry with 1 Changeover
17.5mm housing



Application

Measuring of three-phase current for symmetry, under voltage < 170V AC Phase – N and phase failure.

Description

The **MMA phase measuring relay / Asymmetry** monitors the phases of a three phase current for symmetry, under voltage < 170V AC phase – N and phase failure. The relay is powered by the connection to phase L1(L1 – N > 170V AC). In addition, the star point (neutral) of the phases to be monitored must be connected. The green LED indicates the connection of the power supply.

Function

The relay switches into its work position, as soon as all three phases exceed 170V AC (phases – N) and the deviation between the phases is less than the voltage asymmetry values selected with the potentiometer. This status is indicated by the red LED. The relay switches into its rest position if at least one of the phases falls below the minimum value of 170V AC (phases – N) or exceeds the selected asymmetry for longer than the selected delay time, the relay switches into its rest position. The MMA senses the phase angle and will also switch off if the user generates a back feed.

Options

Other adjustment ranges available upon request.

Part number

012015 **MMA phase measuring relay**
Asymmetry / 1 Changeover

Approvals



Mounting

Snap-on mounting using a standard DIN rail EN 50022. The unit is designed to allow side-by-side mounting, with an ambient temperature of < 60°C.

Measuring relay
MMA - Phase measuring relay / Asymmetry with 1 Changeover
 17.5mm housing

Technical data

Supply

Supply voltage: 3 x 400V AC / N
 Frequency range: 50 ... 60Hz
 Power consumption: 8VA
 Operating mode: continuous

Adjustment ranges

Asymmetry: 5...40° tolerance 20%
 Delay time: 0.5...10s
 Measuring accuracy: 5% over the entire temperature and voltage range

Repetitive accuracy: ± 2%

Operation indicators

Supply voltage: LED, green
 Relay in work position: LED, red

Contact

Number of changeovers: 1
 Contact material: AgSnO₂
 Maximum switching voltage: 250V AC
 Maximum switching current: 4A
 Drop-off time of switching element: approx. 20ms
 Mechanical life: 30 Mio.
 Electrical life (with rated load): 0.8 Mio.

General data

Ambient temperature: - 25 ... + 60°C
 Climate resistance: VDE 0435T.2021
 Mounting position: any
 Vibration resistance: VDE 0435T.2021
 Test voltage: 2.5kV
 Isolation group: VDE 0110 Group C 250
 Protection class: Terminals IP 20
 Housing IP 40
 Connection terminals: Crosshead screws;
 M3.5 self opening
 Connection cross section: Multi-strand wire with wire sleeves 2 x 2.5mm²
 single wire 2 x 2.5mm²
 VDE 0106T.100 and VBG4
 Finger touch protection:
 Mounting: Symmetrical DIN rail EN 50022
 Dimensions l x w x h: 90mm x 17.5mm x 69.5mm
 Weight: 86g

Example

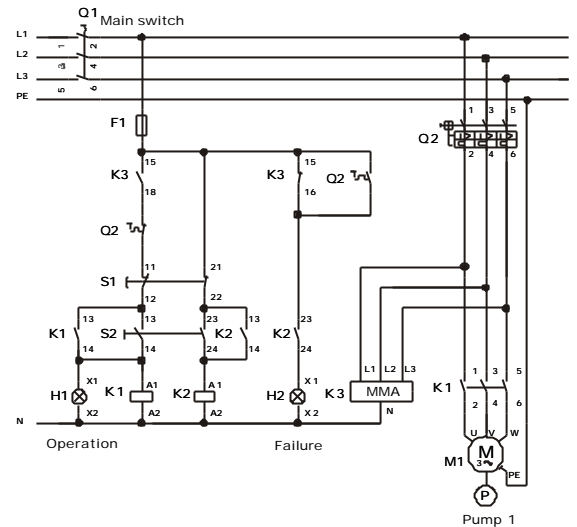

The MMA monitors a pump motor for symmetry.

Dimensions

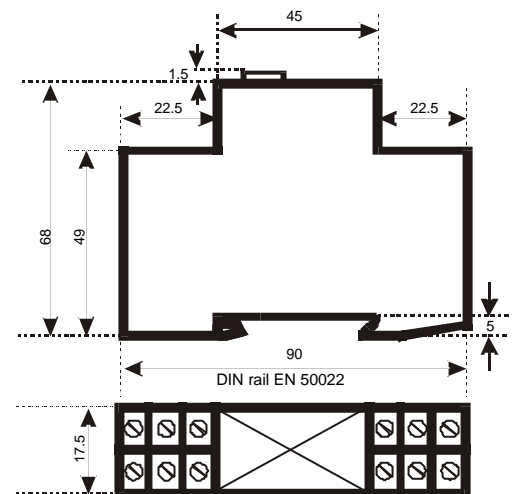

Connections

The terminal assignment for the connections is on the front panel of the relay. **Reading the front panel from top to bottom**, the connections are in the following order:

Upper side	Right:	L2 – N – nc
	Left:	L1 – L3 – nc
Lower side	Right:	nc – 15 – 18
	Left:	nc – nc – 16