

Timer
ZAB1 - Delay-on release with 1 Changeover
 17.5mm housing



Application

Time control

Description

The **ZAB1 Delay-on release timer** offers 16 different timing intervals in one unit. The timing intervals can be adjusted with DIP switches on the front panel of the relay. The timer can operate on either 230V AC using terminals A1 and A2 or 24V DC using terminals A3 and A2. The green LED indicates the connection to the power supply.

Function

Continuous presence of the power supply connected to the terminals A1 and A2 or A3 and A2 is required for timing. The activation of the timing function is accomplished with a potential-free control contact, which is connected to the terminals B1 and B2. If this control contact is closed then the output relay is energized. With the opening of the control contact, the timer is started, and the set time begins to elapse. After the delay time has elapsed, the output relay is de-energized. If during or upon completion of the timing function the control contact is closed and reopened the timing period begins again. This also applies if the supply is disconnected during the timing period.

Options

Other timing ranges and voltages available upon request.

Part number

011208 **ZAB1 Delay-on release**
16 Timing ranges/ 1 Changeover

Timing ranges

16 timing ranges with adjustable DIP switches

0.05 – 1 s	0.5 – 10 min
0.15 – 3 s	1.5 – 30 min
0.5 – 10 s	3 – 60 min
1.5 – 30 s	15 – 300 min
3 – 60 s	0.5 – 10 h
5 – 100 s	1.5 – 30 h
10 – 200 s	3 – 60 h
15 – 300 s	5 – 100 h

DIP switch adjustments

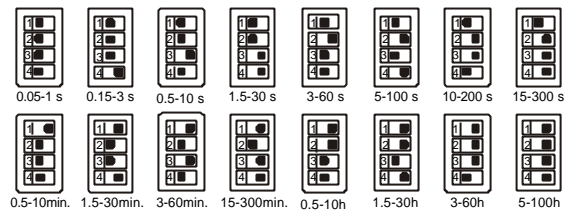

Approvals



Function diagram

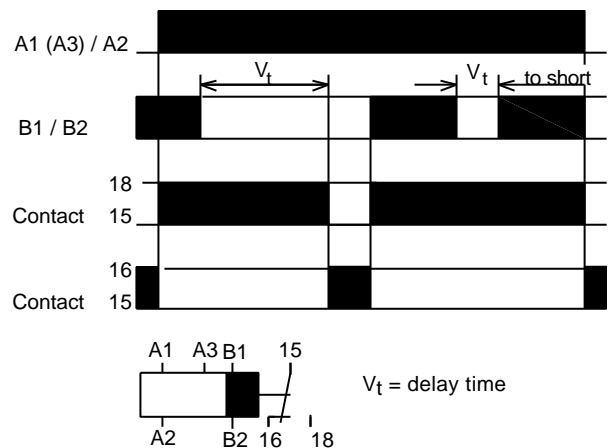

Mounting

Snap-on mounting using a standard DIN rail DIN EN 50022. The unit is designed to allow side-by-side mounting, with an ambient temperature of < 60°C.

Timer
ZAB1 - Delay-on release with 1 Changeover
 17.5mm housing

Technical data

Supply

Supply voltage A1/A2: 230V AC -15 / +10%
 A3/A2: 24V AC/DC -15 / +10%

Frequency range: 0 / 50 ... 60Hz

Power consumption: approx. 1.5W with DC
 approx. 6VA with AC

Operating mode: continuous

Supply voltage influence: < 0.01% over voltage range

Temperature influence: < 0.01%/°C

Recovery time: < 100ms

Repetitive accuracy: ± 0.2%

Operation indicators

Supply voltage: LED, green

Relay in working position: LED, red

Contact

Number of changeovers: 1

Contact material: AgSnO₂

Maximum switching voltage: 250V AC

Maximum switching current: 4A

Drop-off time of switching element: approx. 20ms

Mechanical life: 30 Mio.

Electrical life (with rated load): 0.8 Mio.

General data

Ambient temperature: - 25 ... + 60°C

Climate resistance: VDE 0435T.2021

Mounting position: any

Vibration resistance: VDE 0435T.2021

Test voltage: 2.5kV

Isolation group: VDE 0110 Group C 250

Protection class: Terminals IP 20
 Housing IP 40

Connection terminals: Crosshead screws; M3.5 self-opening

Connection cross section: Multi-strand wire with wire sleeve 2 x 2.5mm²
 single-wire 2 x 2.5mm²

Finger touch protection: VDE 0106T.100 and VBG4

Mounting: Symmetrical rail DIN EN 50022

Dimensions l x w x h: 90mm x 17.5mm x 69.5mm

Weight: 96g

Example

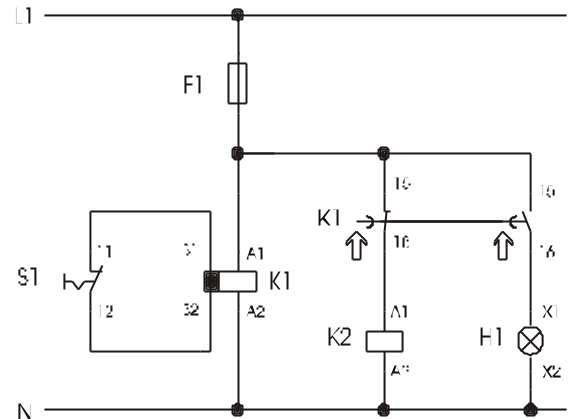

When the contact S1 is opened, K2 releases after the selected delay time and the light H1 comes on.

Dimensions

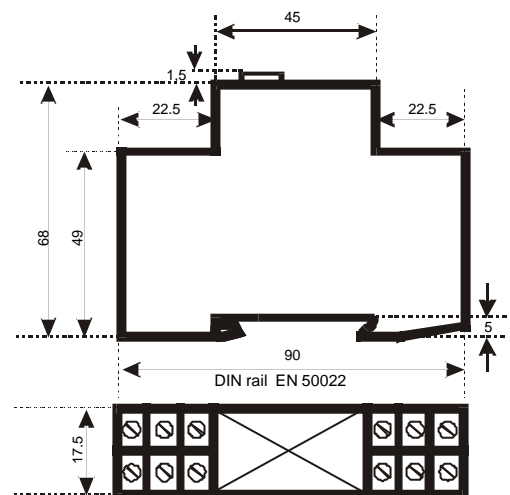

Connections

The terminal assignment for the connections is located on the front panel of the relay. **Reading the front panel from top to bottom**, the connections are in the following order:

LED side	Right:	B1 – nc – A3
	Left:	nc – nc – A1
Potentiometer side	Right:	B2 – 15 – 18
	Left:	nc – A2 – 16